

F94 101 ASSEMBLY INSTRUCTIONS







NOTE: ASSEMBLY ITEMS ARE PROVIDED IN A BAG IN THE BOX







*Headrest assembly items and details are applicable if headrest has been purchased. Item may be supplied in a separate box.

Secure screws tightly or product damage may occur.

Visit hoodseating.com for assembly download documents and for user instructions.



-  5 x CASTORS
-  1 x BASE
-  1 x GAS LIFT
-  1 x SEAT
-  1 x BACK
-  2 x ARMS
-  1 x HEAD-

- | | QTY | ITEM | SIZE |
|---|--------|-----------|--------|
|  | SPARES | | |
|  | A 3 x | M8 | 20mm 1 |
|  | B 6 x | M4 | 35mm 1 |
|  | C 3 x | Washers | |
|  | D 6 x | Washers | |
|  | E 1 x | Badge | |
|  | F 1 x | Allen Key | |

1 Insert castors into underside of base

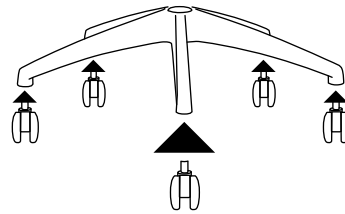

2 Insert gas lift into centre of base

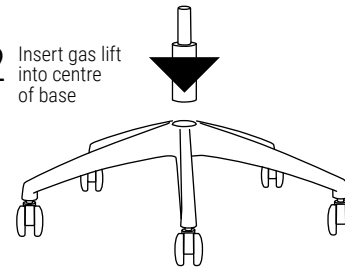

3 Lower seat onto gas lift

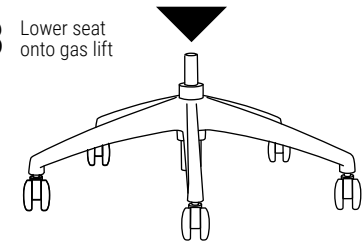

4 Slide backrest onto base and attach

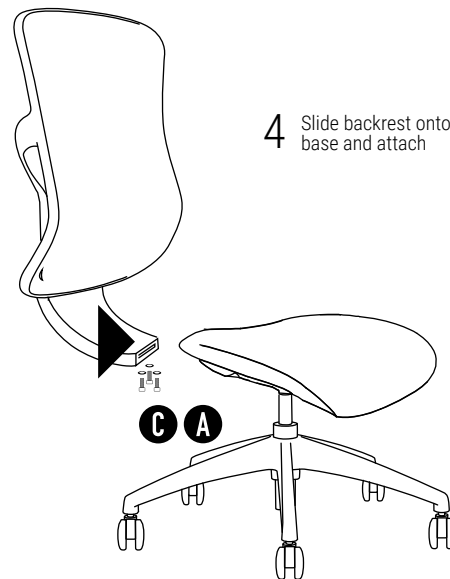

5 Attach arms to side of mechanism

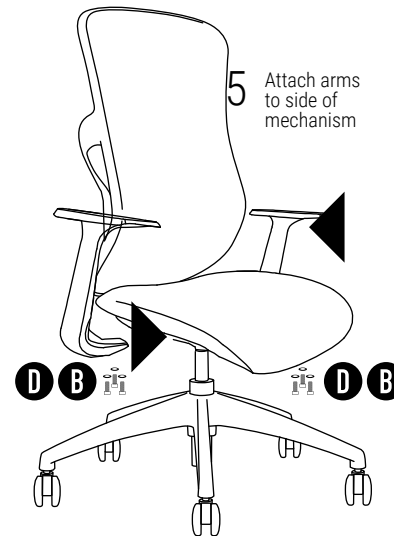

6 Attach headrest* if applicable then apply badge

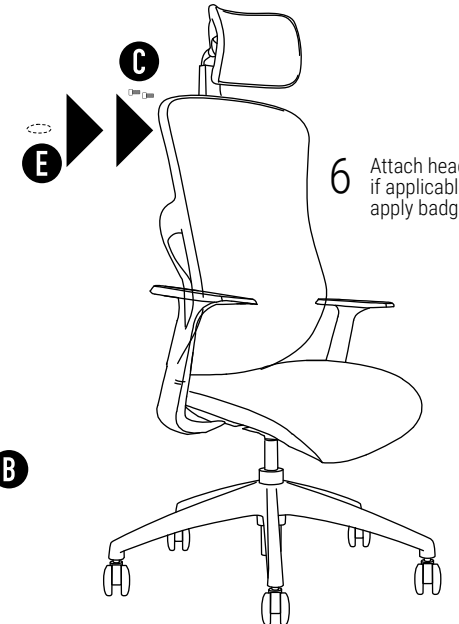







F94 102 ASSEMBLY INSTRUCTIONS







*Headrest assembly items and details are applicable if headrest has been purchased. Item may be supplied in a separate box.

Secure screws tightly or product damage may occur.

Visit hoodseating.com for assembly download



-  5 x CASTORS
-  1 x BASE
-  1 x GAS LIFT
-  1 x SEAT
-  1 x BACK
-  2 x ARMS
-  1 x HEAD-

- QTY ITEM SIZE
-  SPARES
 -  A 3 x M8 20mm 1
 -  B 4x M8 16mm 1
 -  C* 2 x M6 12mm 1
 -  D 9x Washers
 -  E 1 x Badge

1 Insert castors into underside of base

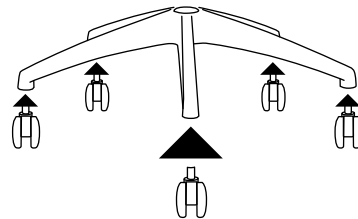

2 Insert gas lift into centre of base

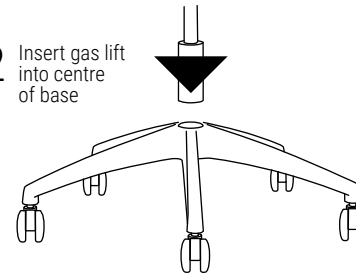

3 Lower seat onto gas lift

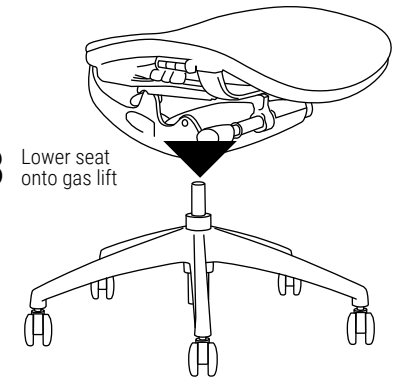

4 Slide backrest onto base and attach

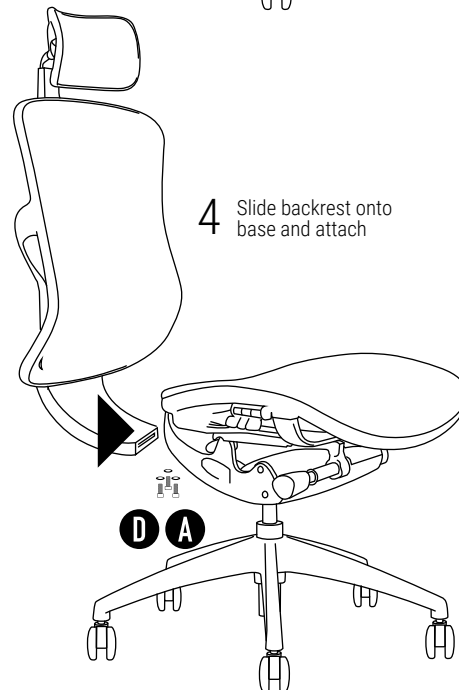

5 Attach arms to side of mechanism

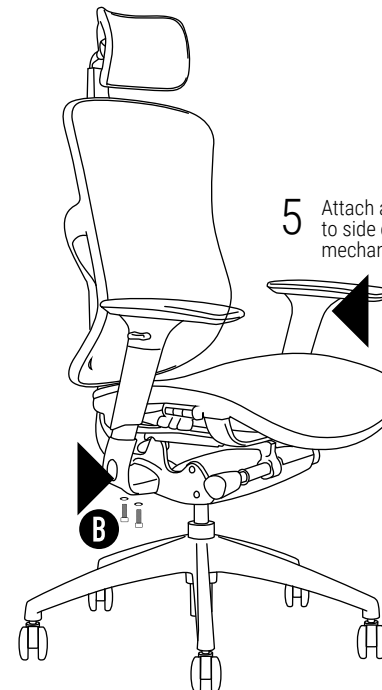

6 Attach headrest* if applicable then apply badge

